

# FBE Series



## CHARACTERISTICS

- 2 222 2 2 2 2 2 2 2 2 2 2 2 2
- 22 2 2 2 2 2 2 2 2 2 2 2
- 22 22 2 222 22 2
- 2 22 2 22 2 2
- 2 2 2 2 2

## APPLICATION

- 22 222 222 22
- 2 2 2 2 2 2 2 2 2 2 2 2

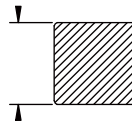
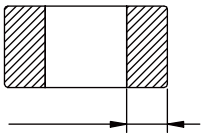

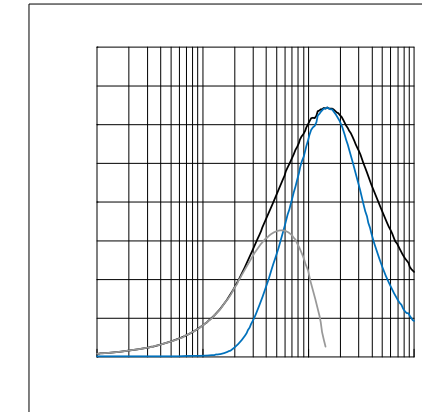
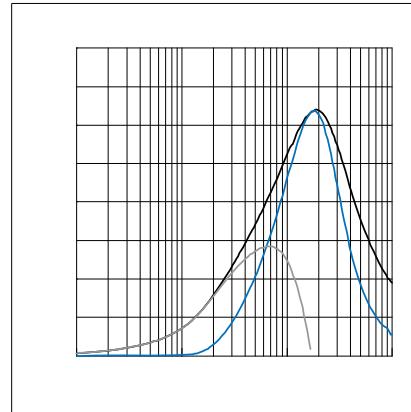
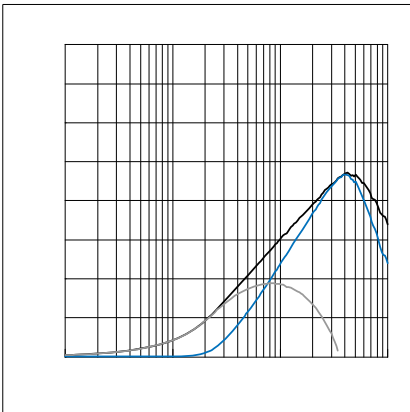
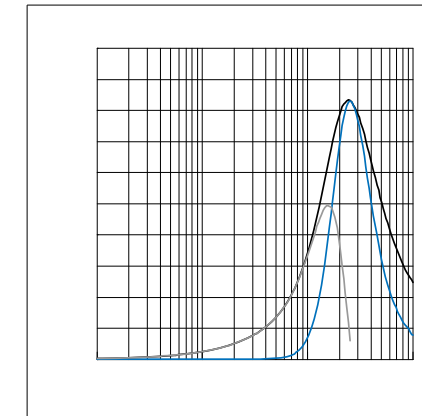
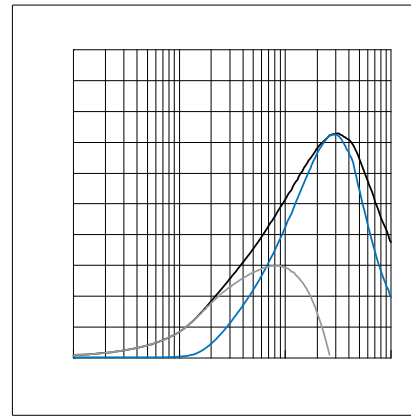
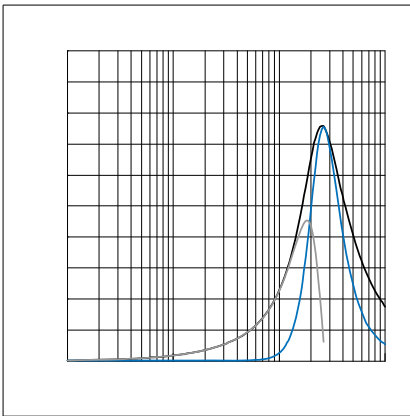
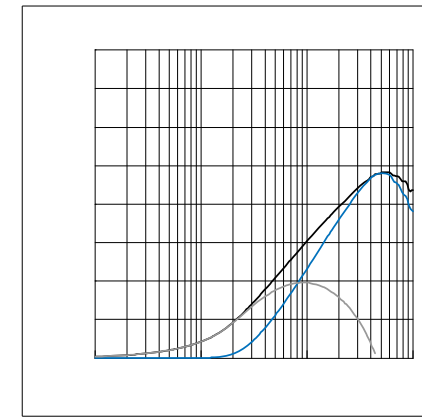
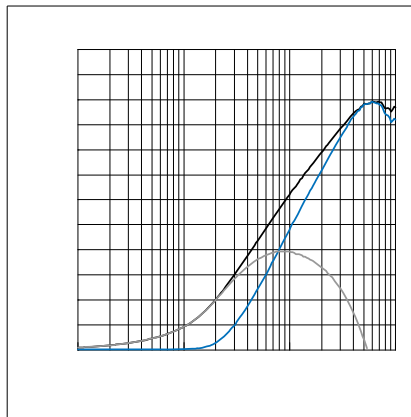
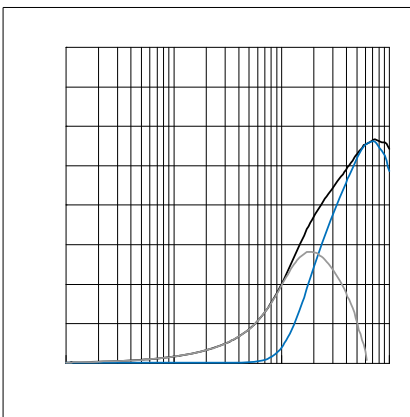
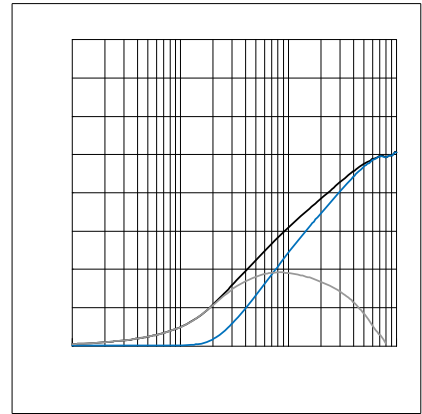
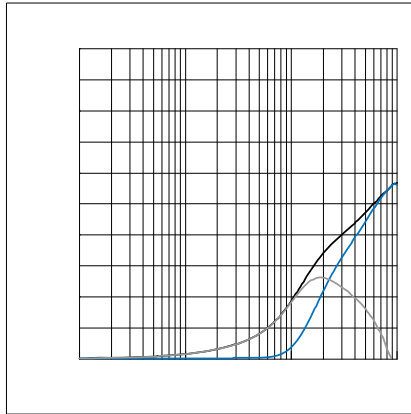
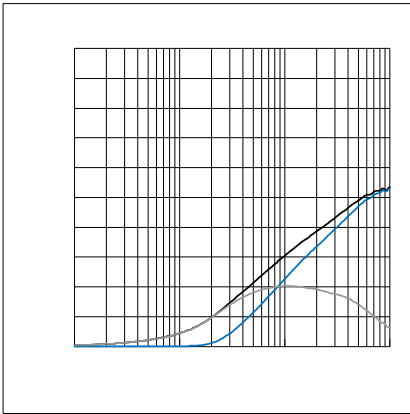

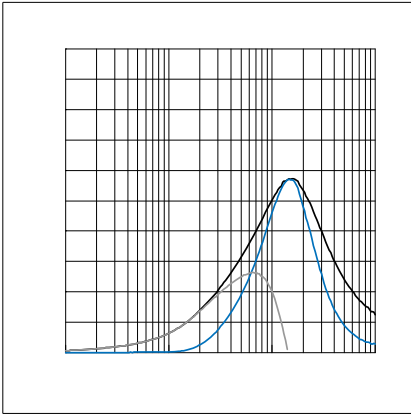

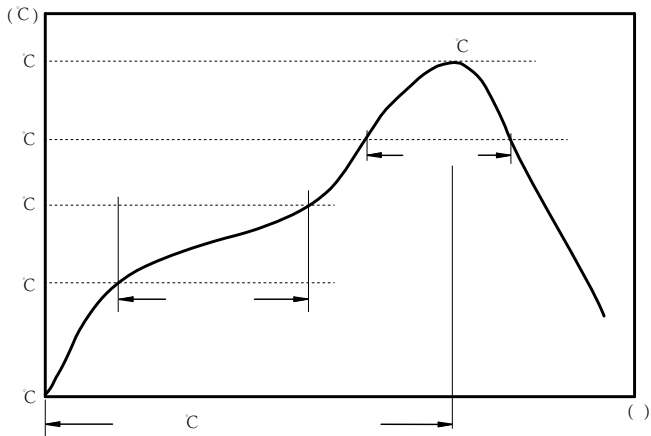

C  
C  
C

:

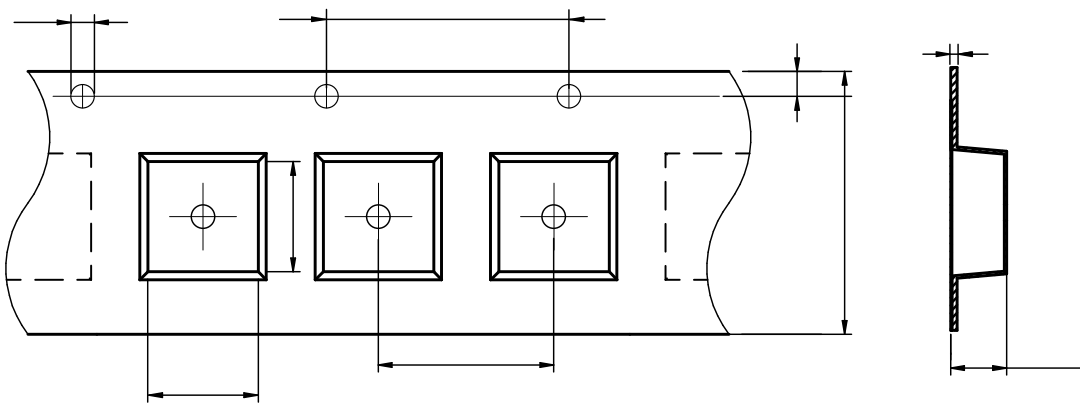

|         |                 |                 |               |               |               |               |                 |                |                 |
|---------|-----------------|-----------------|---------------|---------------|---------------|---------------|-----------------|----------------|-----------------|
| FBE0402 | $0.62 \pm 0.03$ | $1.12 \pm 0.03$ | $1.5 \pm 0.1$ | $4.0 \pm 0.1$ | $4.0 \pm 0.1$ | $8.0 \pm 0.3$ | $0.60 \pm 0.03$ | $1.75 \pm 0.1$ | $0.60 \pm 0.03$ |
|---------|-----------------|-----------------|---------------|---------------|---------------|---------------|-----------------|----------------|-----------------|

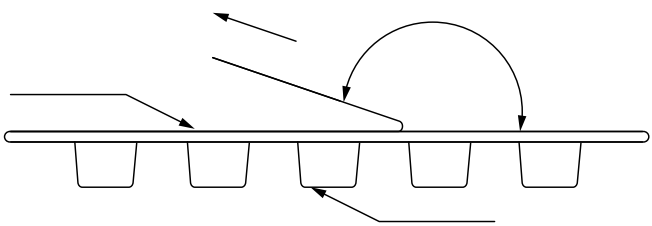

The peel force of top cover tape shall be between 0.14 to 0.58 N

:

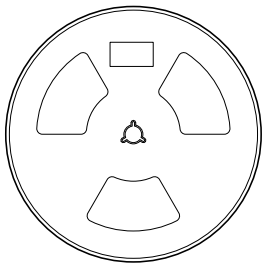
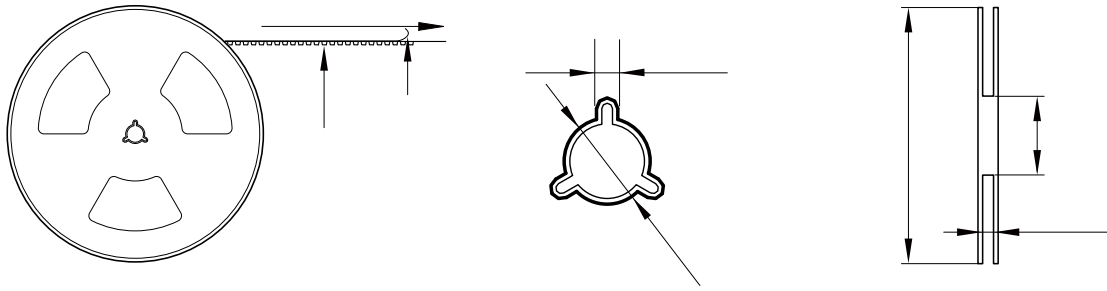

10000 Pcs/Reel

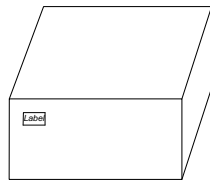

5 Reel /Inner box( 50K Pcs)

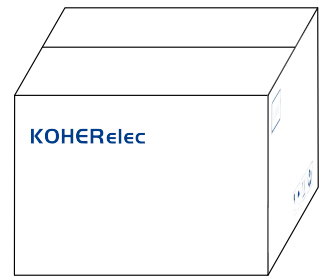

8 Inner box/Carton box(400K Pcs)

:

- 
- 
- 
- 
- 
- 
- 
- 
- 
-